

# Lift Up & Friction Style Floor Locks

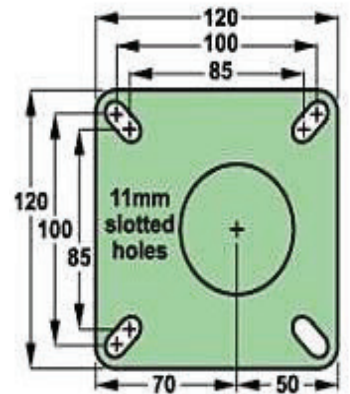
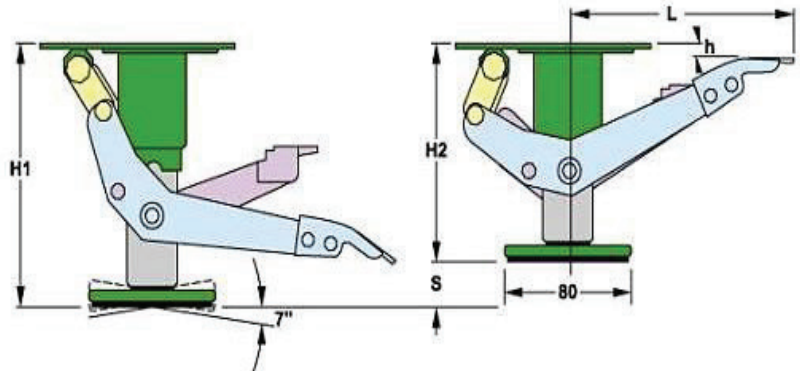
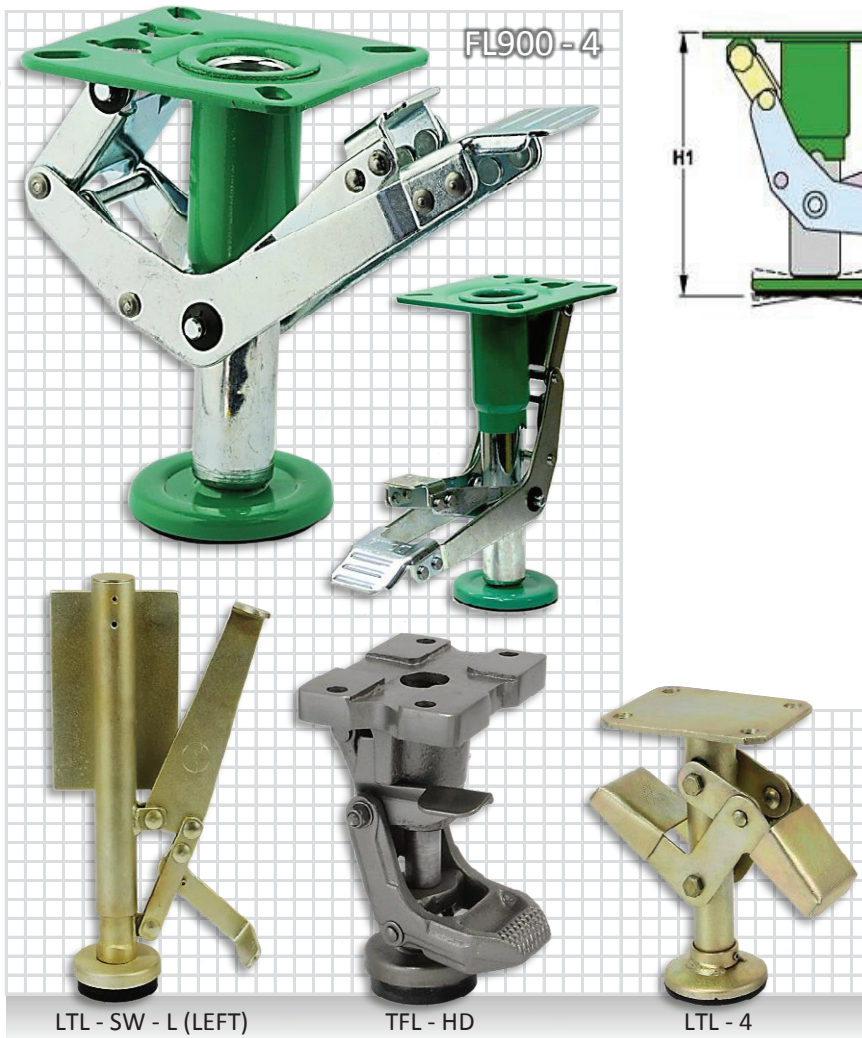

## • FLOOR LOCKS - LIFT UP & HOLD

ITEM CODE	FOR CASTOR SIZE	MOUNTING HEIGHT (mm)	H1 (mm)	H2 (mm)	S (mm)	L (mm)	h (mm)	UNIT WEIGHT (kgs)	LOAD RATING (kgs)
FL900 - 2	4" / 100	148	155	125	30	142	1.5	1.5	200
FL900 - 4	6" / 150	204	211	168	36	142	1.5	1.75	300
FL900 - 6	8" / 200	248	255	212	36	142	3.5	1.9	300

## • TRUCK LOCKS - FRICTION HOLD

ITEM CODE	FULLY EXTENDED HEIGHT (mm)	RETRACTED HEIGHT (mm)	TOP PLATE (mm)	BOLT HOLE CENTRES (mm)	ATTACHING BOLT SIZE (mm)
LTL - 4	146	116	138 X 110	105 X 75 - 80	10
LTL - 6	195	155	138 X 110	105 X 75 - 80	10
LTL - 8	245	205	138 X 110	105 X 75 - 80	10
TFL - HD	205	170	152 X 114	127 X 63.5	12
LTL - SW - L	381	346	165 X 114	TO BE DRILLED ON SITE	N/A
LTL - SW - R	381	346	165 X 114	TO BE DRILLED ON SITE	N/A