

Heavy Industrial CGEHQ SERIES White Nylon on Nylon Centre

100mm, 125mm, 150mm, 200mm



Capacity: 300 – 480KG per castor

- Double Ball Bearing Centres
- White Nylon on Nylon Centre
- Robust Metal Total Brake
- Applications for all industries : Transport, Food & Engineering Industries, Warehousing and many other applications

TYPE	CODE	WHEEL DIAMETER (MM)	TYRE WIDTH	WHEEL TYPE	BEARING TYPE	SWIVEL RADIUS MM	CAPACITY	HEIGHT (MM)
SWIVEL	CGEHWNQ100S	100	50					
SWIVEL / BRAKE	CGEHWNQ100STB	100	50		BALL	81	300	144
FIXED	CGEHWNQ100F	100	50		BALL	129	300	144
SWIVEL	CGEHWNQ125S	125	50		BALL	81	300	144
SWIVEL / BRAKE	CGEHWNQ125STB	125	50		BALL	96	360	165
FIXED	CGEHWNQ125F	125	50		BALL	129	360	165
SWIVEL	CGEHWNQ150S	150	50		BALL	96	360	165
SWIVEL / BRAKE	CGEHWNQ150STB	150	50		BALL	115	430	191
FIXED	CGEHWNQ150F	150	50		BALL	141	430	191
SWIVEL	CGEHWNQ200S	200	50		BALL	115	430	191
SWIVEL / BRAKE	CGEHWNQ200STB	200	50		BALL	150	480	242
FIXED	CGEHWNQ200F	200	50		BALL	150	480	242

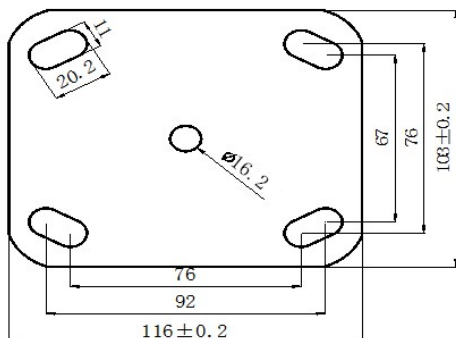

- Spare weldable plates available (CG Platena)